

**Manufacturing Notes:**

- Supplier shall verify actual volume is 37.5Gal minimum
- Material shall be REAL 1.5mm Thick, 304 Stainless Steel
- Break all Sharp Edges and Remove Burrs
- No Seams, Scratches, or Pitting
- No Color Stains or Visable Defects
- No Visable Welds or Slag

A  
B  
C  
D  
E  
F

A  
B  
C  
D  
E  
F

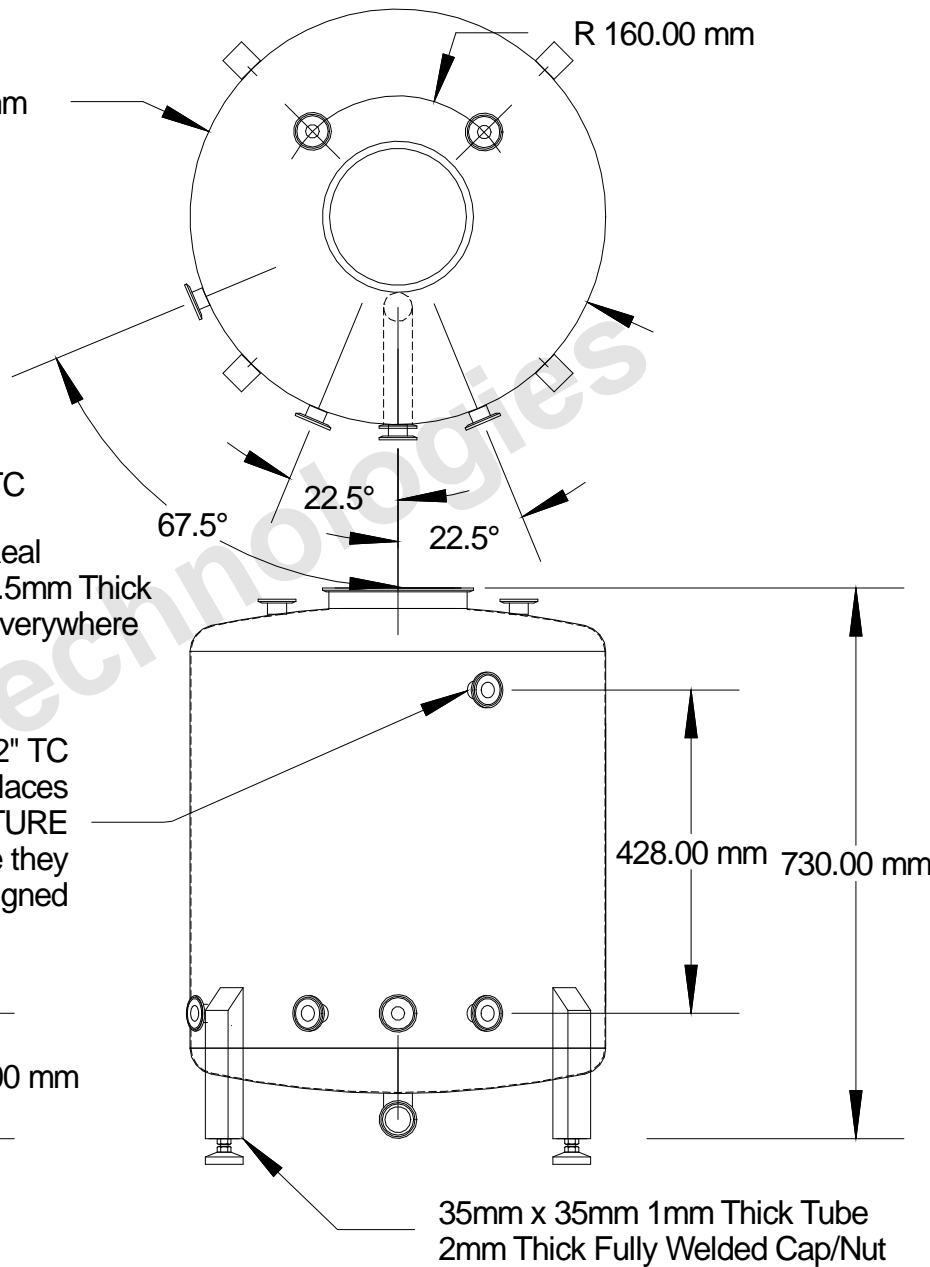
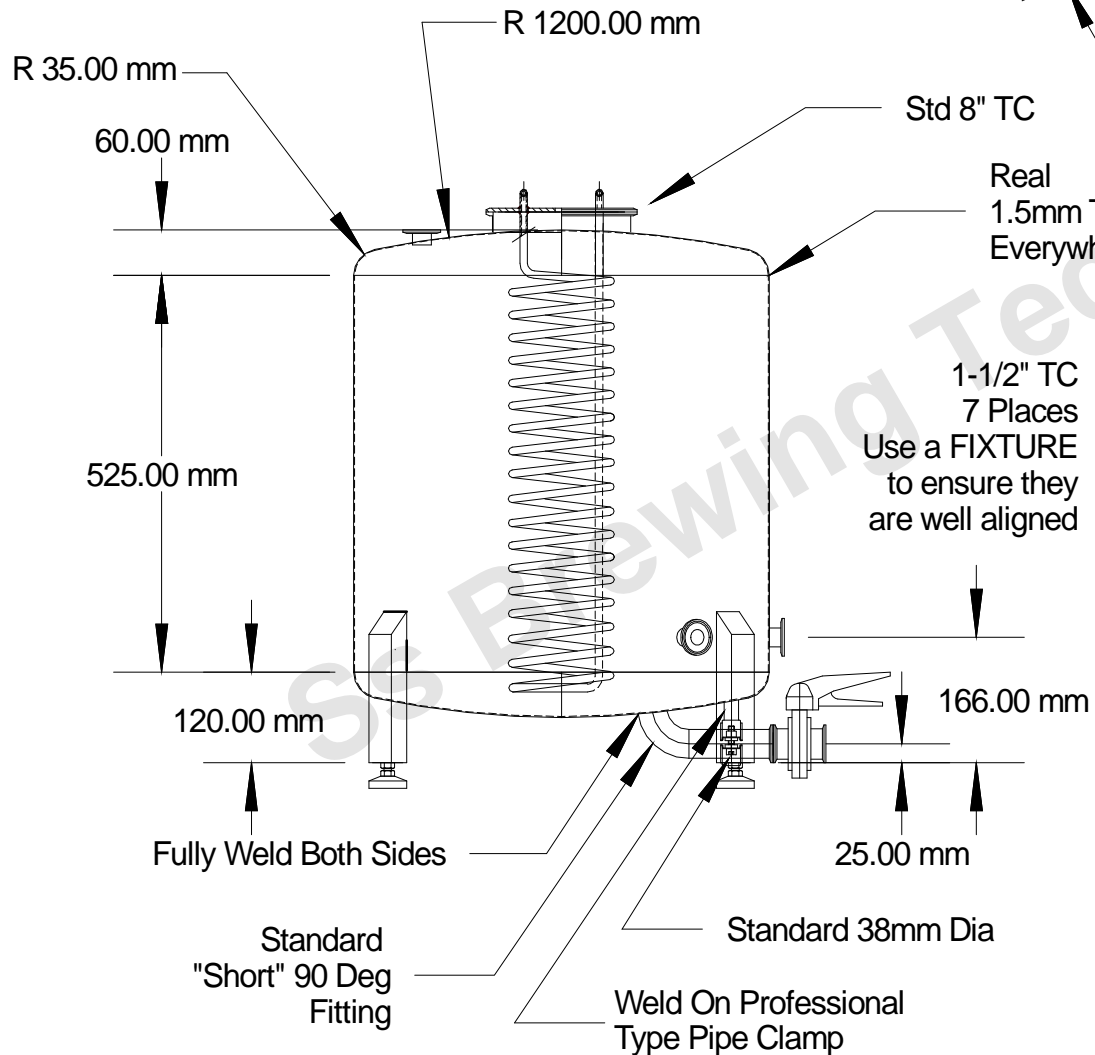

Itemref	Proprietary Design of CM Brewing Technologies Inc.		Article No./Reference	
Designed by C Kucera	Checked by	Approved by - date	Filename SS 1BBL Nano BT	
1 BBL Nano Bright Tank			Ss Brewing Technology	
			SS 17146001	REV C Sheet